

# PDTPR

Intelligent Measuring and Protection Device

PDTPR  
PDTPR  
PSTPR  
PDTPR  
Series

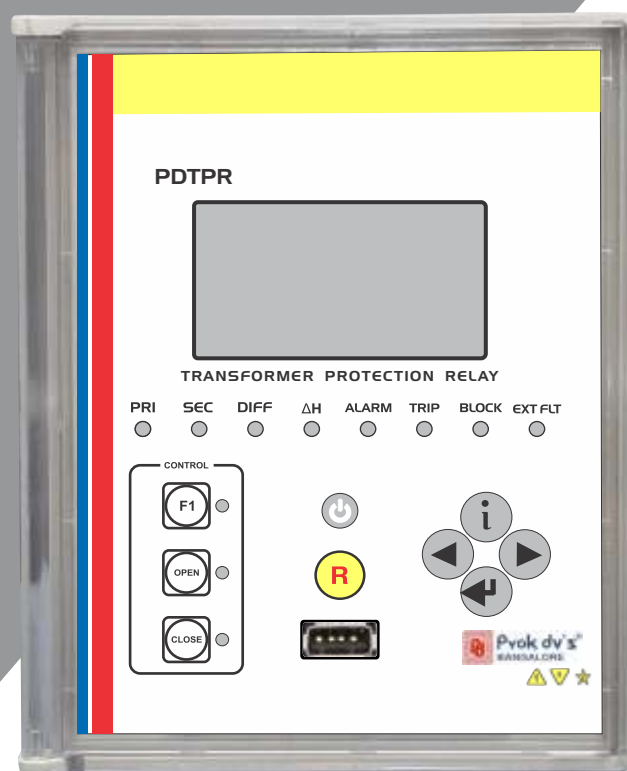

Catalogue

## INDEX

S.No.	Description
1.	Introduction
2.	Application
3.	Hardware
4.	Protection Features
5.	Supervision Functions
6.	Functional Diagram
7.	Protection Functions
8.	Monitoring Functions
9.	Data Acquisition Function
10.	Technical data
11.	Fault Record
12.	Event Record
13.	Human Machine Interface
14.	Communication
15.	Setting Ranges
16.	Technical Data
17.	Standards
	17.1 High Voltage Tests
	17.2 EMC Immunity Tests
	17.3 Environmental Tests
	17.3 Environmental Tests
	17.4 Mechanical Tests
18.	TCS Diagram
19.	Connection Diagram
20.	Dimension Details
21.	Model Selection Guide
21.	Ordering Information

## 1.0 Introduction

PDTPR series offers a multi functional comprehensive smart protection solution for Feeder, Generator, Motor & Transformer segment. PDTPR family of protective relays are advance numerical relays that provide multi protection and monitoring with reliable and fast protection solutions in a single unit.

In this family of PDTPR series, the PDTPRxxx is an advanced transformer protection solution which has fast, sensitive and secure protection for transformer internal & external faults.

PDTPRxxx also provides an automation solution of power control. It complies with IEC60870-5-103, IEC61850, Modbus protocol for high integration of protection & control.

PDTPRxxx offers following model based features to cover requirements of the wide range of users.

- ❖ Programmable Rated Current 1A & 5A for earth, HV & LV winding
- ❖ Measurement, Protection & Metering
- ❖ Draw-out enclosure have modular design with CT shorting
- ❖ Communication (Local & Remote)
- ❖ Disturbance Record
- ❖ Event Record
- ❖ Fault Record
- ❖ DI/DO Matrix Programmability
- ❖ Intelligent key for details of last fault occurred
- ❖ Last 10 fault record (nonvolatile memory) with time stamp
- ❖ PDTPR relays are equipped with self supervision function

## 2.0 Application

PDTPR differential relays are used as the main protection and control units for two winding power transformers, for both internal faults and faults in the influence area of current transformers.

PDTPR units require no interposing transformers to adjust CT Ratio and vector group correction as these adjustments are made by the relay itself in software. For these transformer winding configuration (Vector group Yd1, ---- DD10) & CT ratio are selectable though HMI / USB communication. One has to select correct transformer winding configuration and CT ratio used in the protection scheme.

PDTPR Model

PDTPR is available in following models: -

PDTPR140: For 2-winding transformer protection

(See table 23, 24)

PDTPR170....

PDTPR200....

## 3.0 Hardware

- ❖ Digital Signal Processor based numeric design
- ❖ Measures true RMS with DFT filter
- ❖ 1A & 5A common current terminal & programmable
- ❖ Either 7 current analog inputs OR 6 current analog inputs + 1 voltage analog input
- ❖ Big alpha-numeric (16x4) LCD
- ❖ Max. 6 digital inputs
- ❖ Max. 6 digital outputs
- ❖ 8 LED's at Pk up & Trip on fault + 3 LED's with special function of 3 control keys
- ❖ LAN-RJ45/RS485/USB ports for Communication
- ❖ 16x4 Alpha numeric LCD
- ❖ 8 Push button on the front for MMI

## 4.0 Supervision Functions

- ❖ Lock out Relay
- ❖ Open-Close Breaker Command
- ❖ Trip circuit supervision (74TC)

## 5.0 Protection Features

- ❖ Three phase differential protection (87) with harmonic restrain
- ❖ Three phase Instantaneous differential protection (87)
- ❖ Restricted earth protection (87G) on either Primary or Secondary (MMI selection)
- ❖ Three phase time and instantaneous over current (50/51) protection (HV & LV side)
- ❖ Ground time (51G) and instantaneous over current protection (50G) (either HV or LV side)
- ❖ Current unbalance (46) (HV & LV side)
- ❖ Breaker failure (50BF) (HV & LV side)
- ❖ Trip circuit supervision (HV or LV side)
- ❖ Event recorder
- ❖ Fault recorder
- ❖ DO programmable matrix
- ❖ DI programmable matrix
- ❖ Oscilloscope data recording
- ❖ Multi protocol communication MODBUS-RTU, IEC-103, 101, IEC-61850
- ❖ Time synchronization via SNTP
- ❖ Two setting groups
- ❖ Breaker control (open/closed) using front keys
- ❖ Function key programmable for various functions

## 6.0 Functional Diagram

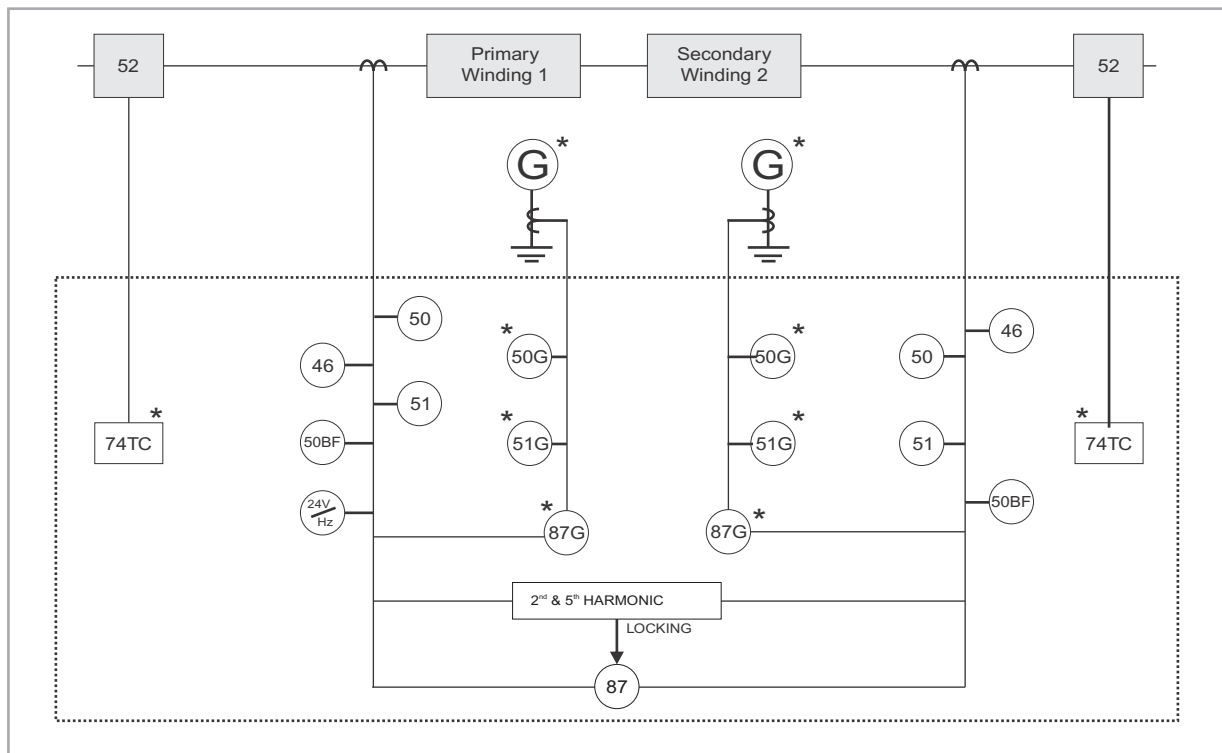

(Figure-2) Functional Diagram

\* Any one side only (Primary or secondary)

## 7.0 Protection Functions

The PDTPR is a numerical multi functional relay ideally suited for the protection of any two winding transformer against two phase internal faults, inter-turn faults and ground faults as well as over current protection for both phase faults and earth faults separately for each transformer winding on primary and secondary.

### Percent Differential Protection (87)

PDTPR unit has dual slope characteristic for differential protection with programmable percentage slope settings, adjustable slope breakpoints, and adjustable additional time delay. This unit provides programmable CT ratio correction factor for primary and secondary side of transformer and CT connection configurations through programmable vector groups. For this protection setting refer table -6

The differential unit operation characteristic is as shown below (See Figure-3).

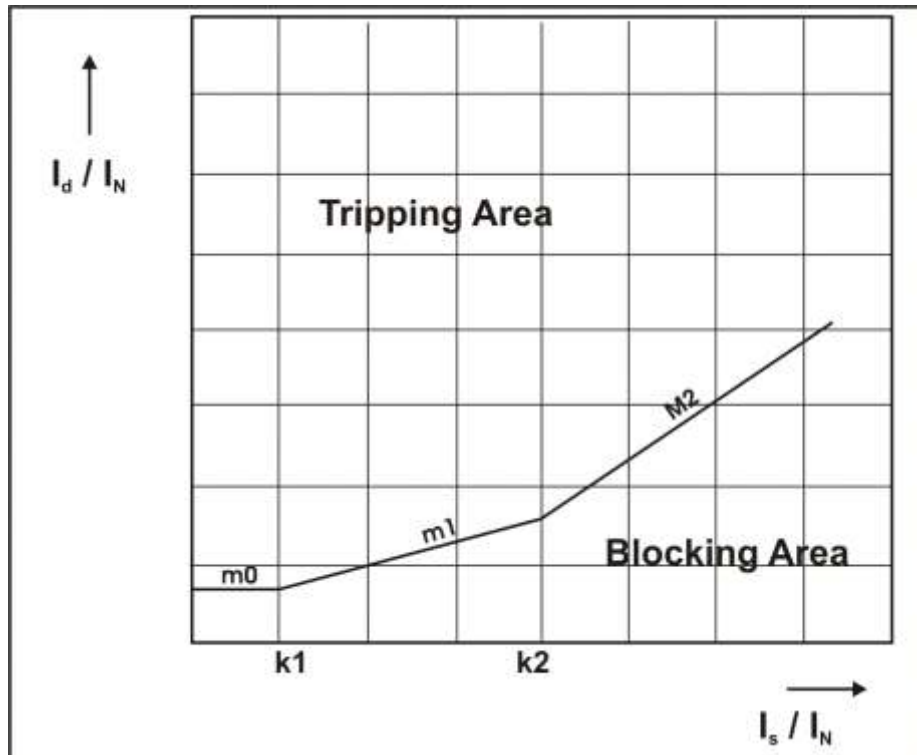

Differential protection operation characteristic  
(Figure-3)

### Harmonic Restrain

Harmonic component of the differential current (2nd & 5th for each phase, whereas 2nd & 3rd for earth) is calculated & extracted using Digital Fourier transforms. The magnitude of these current is used to discriminate between faults and inrush conditions that will restrain differential function during inrush caused by energization and over excitation.

If blocking on harmonic setting is enabled then the relay blocks all the tripping operations when if 2nd/5th harmonic for phase & 2nd & 3rd for earth are higher than the set values. For Harmonic restraint settings refer Table – 7.

### Instantaneous Differential Protection

Tripping occurs when the differential current exceeds the set limit for the selected duration. Refer Table – 6 for these selections. Instantaneous differential protection does not have harmonic restraint.

### Restricted Earth Protection (87G) \*

Earth protection (50G, 51G) will be available either to winding 1 or winding 2 which is selectable.

This function is applicable when a transformer winding is earthed. REF is based on comparing the vector sum of the phase currents of the transformer winding to neutral point current. If the difference ( $I_{ref}$ ) is greater than the calculated value then tripping occurs.

The restricted earth unit operation characteristic is shown below (See Figure-4). For Restricted earth protection settings Refer Table – 8.

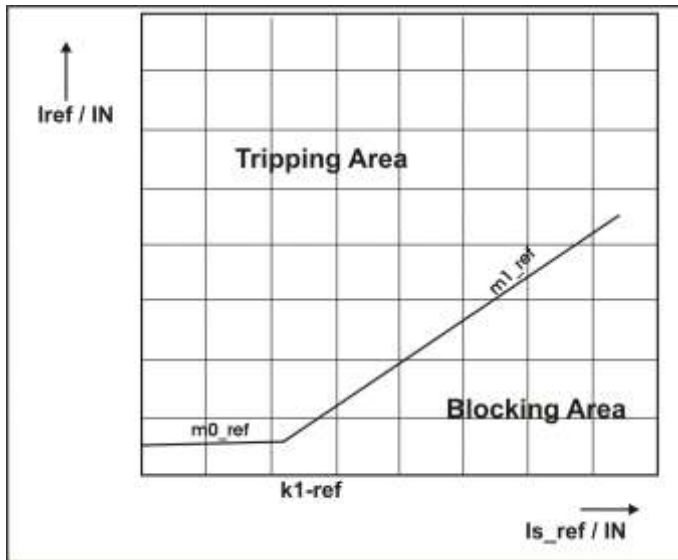

Restricted earth protection operation characteristic (Figure-4)

### Phase Over-current (50/51)

This protection gives backup protection for transformer external faults. If the external faults are not cleared by the primary protections, this overcurrent unit will actuate, otherwise the transformer will be seriously damaged due to overloads. Each winding has overload as well as short-circuit protection. Refer Table – 1 for these protection settings.

### Ground Over-current (50G/51G) \*

This is an overcurrent function used on the current measured at the grounding of a power transformer in order to detect faults to earth. Each winding features has Earth low and Earth hi-set protections. Refer Table – 2 for these protection settings.

### Neutral Over current (50N/51N)

This is an overcurrent function applied to the vectorial sum of phase currents, being its function to detect faults to earth.

### Current Unbalance (46)

This function protects against current unbalances resulting from anomalies in the power system or unbalanced loads. Refer Table – 5 for these protection settings.

### Circuit Breaker Failure Protection (50BF)

The CB Failure Protection is based on supervision of phase currents and earth current after tripping events. The test criterion is whether all phase currents have dropped to less than 5% of IN within the set time (tCBFP). If one or more of the phase currents have not dropped to specified current within this time, CB failure is detected and the assigned output relay is activated. Refer Table – 4 for this protection setting.

### Over Excitation Protection (24)

The over excitation unit prevents transformers from working at a greater flux density than that for which they were designed. It will avoid heating's and consequent damage in the transformer due to over excitation. This unit is based on V / Hz over excitation detection method with two independent levels

## Automation

### Lockout Relay (86)

Relays programmed with this function will act when the differential unit acts (instantaneous or percentage type) so that they can be used as a locking device for breaker close circuits.

### Protection Function Locking

Each protection function can be locked via a digital input as selected and assigned in HMI (Refer Table – 9).

\* **Note: These are the model dependent and are available in auxiliary models only.**

## 8.0 Monitoring Functions

### Trip Circuit Supervision (74TC)

This feature detects any anomalies in the circuit with the switch open or close. It detects trip circuit supply failure of circuit breaker, tripping mechanism failure like circuit breaker contact degeneration in wires, contacts and coils. Refer Table – 3 for these protection settings.

## 9.0 Data Acquisition Function

### Measurements

- ❖ L1, L2, L3 phase current measurements in HV winding
- ❖ L1, L2, L3 phase current measurements in LV winding
- ❖ L1, L2, L3 differential current measurements
- ❖ Earth current measurement
- ❖ Restricted earth current measurement
- ❖ Negative phase sequence in HV & LV side
- ❖ Trip counter (Increments whenever any DO trip due to some fault)
- ❖ Origin of last fault

### Disturbance Record

The PDTPR relay has an oscillograph data recorder with the following characteristics:

- ❖ Oscilloscopic recording can trigger on Pickup or on trip or via DI i.e. change from pre-fault to post-fault stage. It is programmable (Refer Table-14).
- ❖ Each record comprises the samples from 7 analog signals and the status of 6 digital inputs and 6 digital outputs. There will be 30 samples per cycle.
- ❖ Relay saves maximum 1200 cycles, and the number of cycles per record is programmable (for example: if 40 cycles are selected, then there will be maximum 30 records of 40 cycles each).
- ❖ The pre-fault and post-fault cycles are programmable (Refer Table-14).
- ❖ Records are in the non volatile memory.
- ❖ The records are transferred to PC using USB interface. The data is graphically displayed and can be taken on printer (See Fig-5).
- ❖ Record 1 is always latest record. 2nd record is older than 1st..... and so on.
- ❖ Disturbance record in comtrade format as per IEC60255-24.

## 10.0 Technical Data

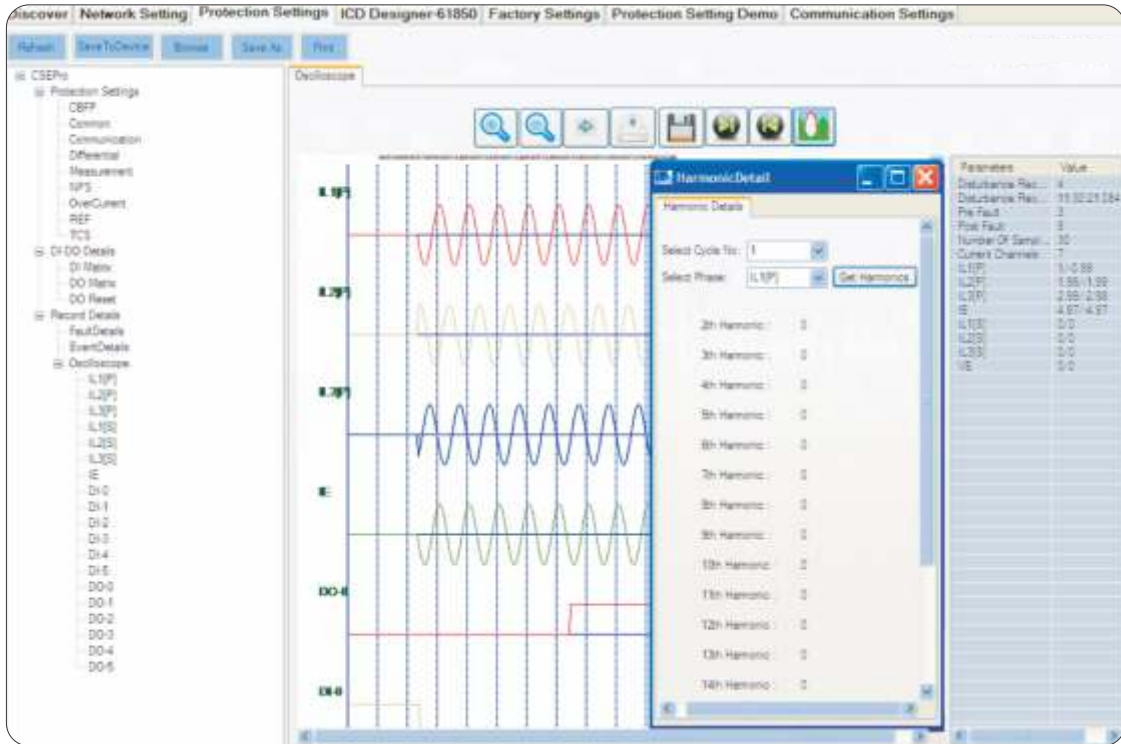

(Figure-5) Oscilloscope recording on PC software

## 11.0 Fault Record

PDTPR records last 10 faults in its non volatile memory with its time stamp. The fault current reading shown by our relay are on the secondary side. Each record has the following information:

### Fault Format

IL1[P]	:	00.00A	Ie	:	00.00A
IL2[P]	:	00.00A	I2[P]	:	00.00A
IL3[P]	:	00.00A	I2[S]	:	00.00A
IL1[S]	:	00.00A	L1[2H]	:	00.00A
IL2[S]	:	00.00A	L2[2H]	:	00.00A
IL3[S]	:	00.00A	L3[2H]	:	00.00A
IL1[D]	:	00.00A	L1[5H]	:	00.00A
IL2[D]	:	00.00A	L2[5H]	:	00.00A
IL3[D]	:	00.00A	L3[5H]	:	00.00A
L1[RES]	:	00.00A	HR MIN	:	HH:MIN
L2[RES]	:	00.00A	SEC Ms	:	Sec: mSec
L3[RES]	:	00.00A	DATE	:	DD:MM:YR
Iref	:	00.00A	F-TYPE	:	Type of fault

Where: -

- ILx[P] Magnitude of phase currents on primary winding
- ILx[S] Magnitude of phase currents on secondary winding
- ILx[D] Magnitude of phase differential currents
- Lx[RES] Magnitude of phase restraining currents
- I2[P] Magnitude of Negative phase sequence on primary winding
- I2[S] Magnitude of Negative phase sequence on secondary winding
- Iref Restricted earth fault current
- Ie Earth current
- Lx[2H] Magnitude of Second harmonic on differential current (each phase)
- Lx[5H] Magnitude of Fifth harmonic on differential current (each phase)
- F-Type Origin of fault (I>, I>>, Ie>, Ie>>, Id>, Id>>, Iref>, I2>, ----- etc.)

When the available memory space is exhausted the new fault automatically over writes the oldest fault.

When the relay trips the description of fault in the transformer will appears on the LCD screen automatically and by pressing 'I' key one can easily get all the detailed information of that fault.

The user can view fault records either via the front USB interface software or remotely via the RS-485 communication.

(See Figure-6).

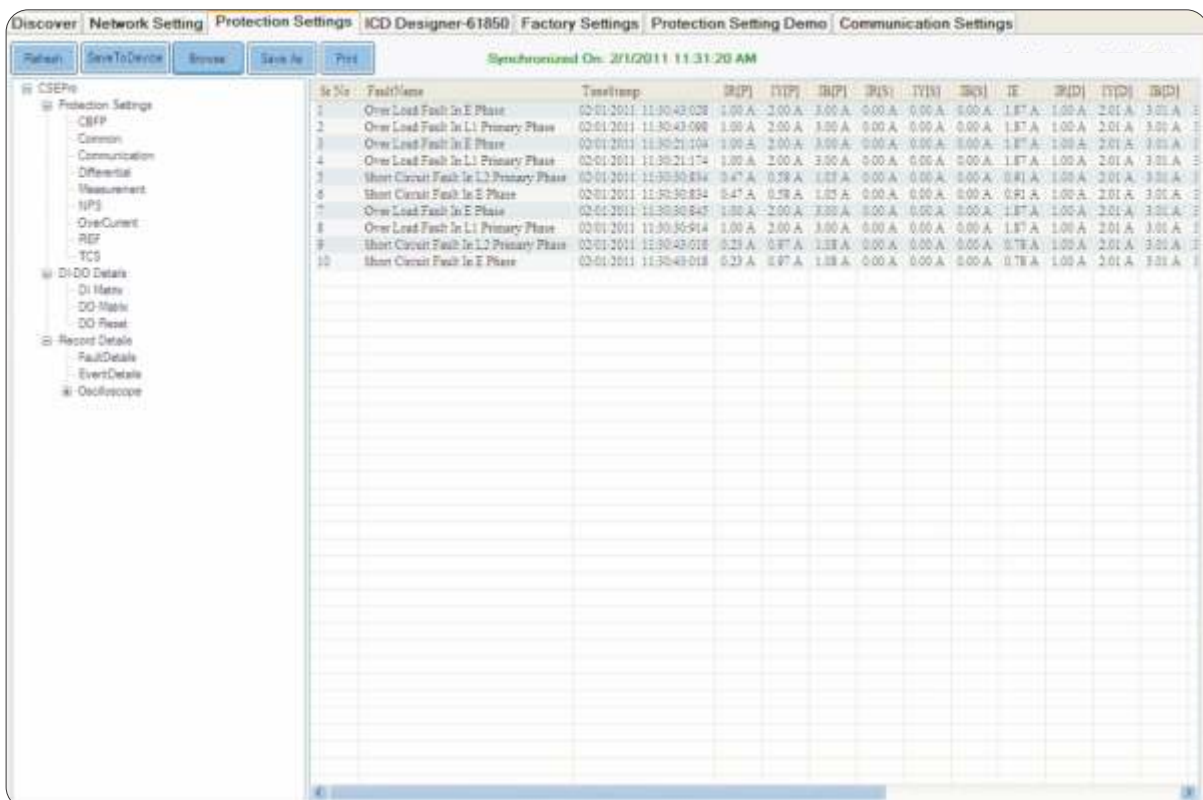

Sr No	Fault Name	Time/Temp	I1(P)	I1(S)	I2(P)	I2(S)	I3(P)	I3(S)	Ie	I2(D)	I1(D)	I3(D)
1	Over Load Fault In E Phase	02/01/2011 11:30:43:028	1.00 A	2.00 A	3.00 A	0.00 A	0.00 A	0.00 A	1.87 A	1.00 A	2.01 A	3.01 A
2	Over Load Fault In L1 Primary Phase	02/01/2011 11:30:43:090	1.00 A	2.00 A	3.00 A	0.00 A	0.00 A	0.00 A	1.87 A	1.00 A	2.01 A	3.01 A
3	Over Load Fault In E Phase	02/01/2011 11:30:21:104	1.00 A	2.00 A	3.00 A	0.00 A	0.00 A	0.00 A	1.87 A	1.00 A	2.01 A	3.01 A
4	Over Load Fault In L1 Primary Phase	02/01/2011 11:30:21:174	1.00 A	2.00 A	3.00 A	0.00 A	0.00 A	0.00 A	1.87 A	1.00 A	2.01 A	3.01 A
5	Short Circuit Fault In L3 Primary Phase	02/01/2011 11:30:30:834	0.47 A	0.78 A	1.03 A	0.00 A	0.00 A	0.00 A	0.81 A	1.00 A	2.01 A	3.01 A
6	Short Circuit Fault In E Phase	02/01/2011 11:30:30:854	0.47 A	0.78 A	1.03 A	0.00 A	0.00 A	0.00 A	0.81 A	1.00 A	2.01 A	3.01 A
7	Over Load Fault In E Phase	02/01/2011 11:30:30:947	1.00 A	2.00 A	3.00 A	0.00 A	0.00 A	0.00 A	1.87 A	1.00 A	2.01 A	3.01 A
8	Over Load Fault In L1 Primary Phase	02/01/2011 11:30:35:914	1.00 A	2.00 A	3.00 A	0.00 A	0.00 A	0.00 A	1.87 A	1.00 A	2.01 A	3.01 A
9	Short Circuit Fault In L2 Primary Phase	02/01/2011 11:30:43:018	0.23 A	0.37 A	1.03 A	0.00 A	0.00 A	0.00 A	0.78 A	1.00 A	2.01 A	3.01 A
10	Short Circuit Fault In E Phase	02/01/2011 11:30:43:018	0.23 A	0.37 A	1.03 A	0.00 A	0.00 A	0.00 A	0.78 A	1.00 A	2.01 A	3.01 A

(Figure-6) Fault Data recording on PC software



## 12.0 Event Record

The unit stores in non volatile memory the last 100 events with it's time stamp. When the available memory space is exhausted, the new event automatically overwrites the oldest event, which can be retrieved from a PC, with the following format:

EVENT : EVENT NUMBER  
 HOUR : HH.MM  
 SEC:mSEC : SEC:mSEC  
 DATE : DD/MM/YY

The user can view event records via the front USB interface software (See Figure-7)

- Description of event number available in event list or in front end software.

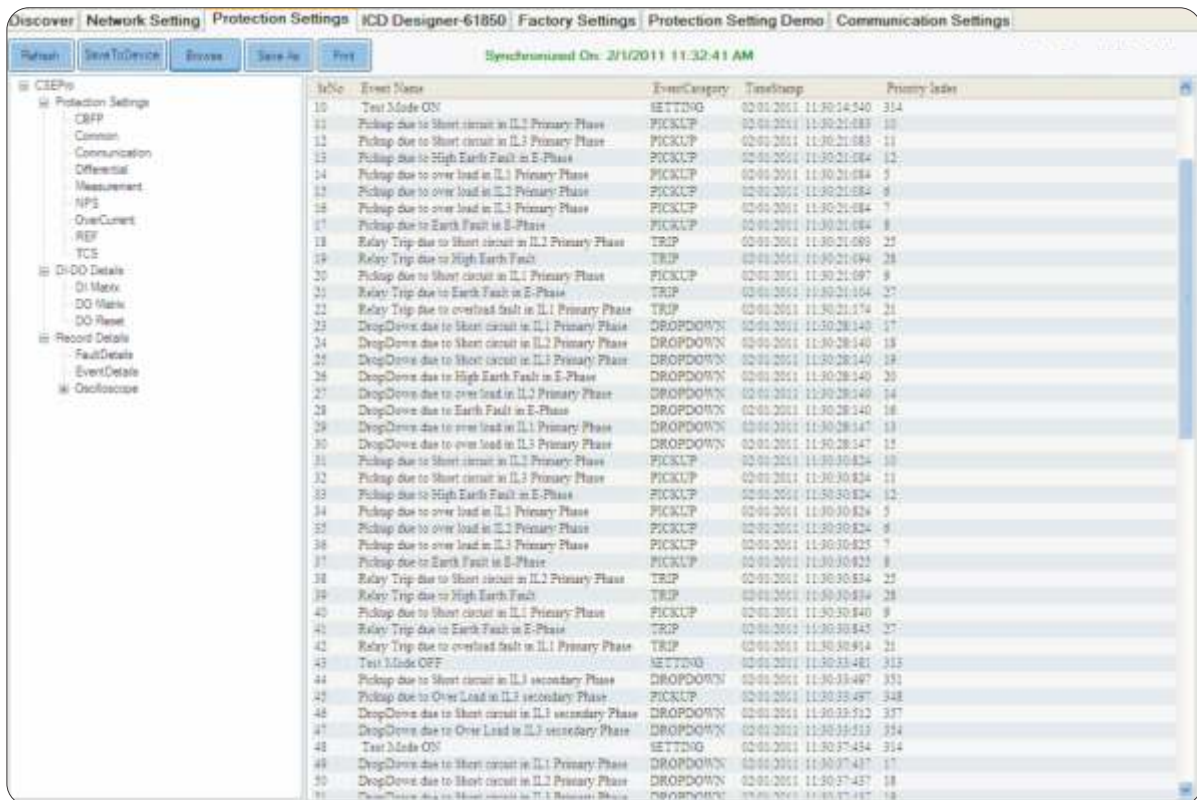

SNo	Event Name	Event Category	Timestamp	Priority Index
10	Test Mode ON	SETTING	02/01/2011 11:30:14:040	314
11	Pickup due to Short circuit in IL3 Primary Phase	PICKUP	02/01/2011 11:30:21:089	10
12	Pickup due to Short circuit in IL3 Primary Phase	PICKUP	02/01/2011 11:30:21:089	11
13	Pickup due to High Earth Fault in E-Phase	PICKUP	02/01/2011 11:30:21:084	12
14	Pickup due to over load in IL1 Primary Phase	PICKUP	02/01/2011 11:30:21:084	5
15	Pickup due to over load in IL3 Primary Phase	PICKUP	02/01/2011 11:30:21:084	6
16	Pickup due to over load in IL3 Primary Phase	PICKUP	02/01/2011 11:30:21:084	7
17	Pickup due to Earth Fault in E-Phase	PICKUP	02/01/2011 11:30:21:084	8
18	Relay Trip due to Short circuit in IL3 Primary Phase	TRIP	02/01/2011 11:30:21:090	25
19	Relay Trip due to High Earth Fault	TRIP	02/01/2011 11:30:21:094	28
20	Pickup due to Short circuit in IL1 Primary Phase	PICKUP	02/01/2011 11:30:21:097	9
21	Relay Trip due to Earth Fault in E-Phase	TRIP	02/01/2011 11:30:21:104	27
22	Relay Trip due to over load fault in IL1 Primary Phase	TRIP	02/01/2011 11:30:21:114	21
23	DropDown due to Short circuit in IL1 Primary Phase	DROPDOWN	02/01/2011 11:30:28:140	17
24	DropDown due to Short circuit in IL3 Primary Phase	DROPDOWN	02/01/2011 11:30:28:140	18
25	DropDown due to Short circuit in IL3 Primary Phase	DROPDOWN	02/01/2011 11:30:28:140	19
26	DropDown due to High Earth Fault in E-Phase	DROPDOWN	02/01/2011 11:30:28:140	20
27	DropDown due to over load in IL1 Primary Phase	DROPDOWN	02/01/2011 11:30:28:140	14
28	DropDown due to Earth Fault in E-Phase	DROPDOWN	02/01/2011 11:30:28:140	16
29	DropDown due to over load in IL1 Primary Phase	DROPDOWN	02/01/2011 11:30:28:147	13
30	DropDown due to over load in IL3 Primary Phase	DROPDOWN	02/01/2011 11:30:28:147	15
31	Pickup due to Short circuit in IL3 Primary Phase	PICKUP	02/01/2011 11:30:30:824	10
32	Pickup due to Short circuit in IL3 Primary Phase	PICKUP	02/01/2011 11:30:30:824	11
33	Pickup due to High Earth Fault in E-Phase	PICKUP	02/01/2011 11:30:30:824	12
34	Pickup due to over load in IL1 Primary Phase	PICKUP	02/01/2011 11:30:30:824	5
35	Pickup due to over load in IL3 Primary Phase	PICKUP	02/01/2011 11:30:30:824	6
36	Pickup due to over load in IL3 Primary Phase	PICKUP	02/01/2011 11:30:30:825	7
37	Pickup due to Earth Fault in E-Phase	PICKUP	02/01/2011 11:30:30:825	8
38	Relay Trip due to Short circuit in IL3 Primary Phase	TRIP	02/01/2011 11:30:30:834	25
39	Relay Trip due to High Earth Fault	TRIP	02/01/2011 11:30:30:839	28
40	Pickup due to Short circuit in IL1 Primary Phase	PICKUP	02/01/2011 11:30:30:840	9
41	Relay Trip due to Earth Fault in E-Phase	TRIP	02/01/2011 11:30:30:843	27
42	Relay Trip due to over load fault in IL1 Primary Phase	TRIP	02/01/2011 11:30:30:854	21
43	Test Mode OFF	SETTING	02/01/2011 11:30:33:481	313
44	Pickup due to Short circuit in IL3 secondary Phase	DROPDOWN	02/01/2011 11:30:33:487	351
45	Pickup due to Over Load in IL3 secondary Phase	PICKUP	02/01/2011 11:30:33:487	348
46	DropDown due to Short circuit in IL1 secondary Phase	DROPDOWN	02/01/2011 11:30:33:513	357
47	DropDown due to Over Load in IL3 secondary Phase	DROPDOWN	02/01/2011 11:30:33:513	354
48	Test Mode ON	SETTING	02/01/2011 11:30:37:454	314
49	DropDown due to Short circuit in IL1 Primary Phase	DROPDOWN	02/01/2011 11:30:37:437	17
50	DropDown due to Short circuit in IL2 Primary Phase	DROPDOWN	02/01/2011 11:30:37:457	18
51	DropDown due to Short circuit in IL1 Secondary Phase	DROPDOWN	02/01/2011 11:30:37:457	18

(Figure-7) Event Data recording on PC Software

### Output Contacts

No. of digital outputs : 6 (DO1, DO2, DO3, DO4, DO5, DO6) for PDTPR 170 & 200 model  
 : 4 (DO1, DO2, DO3, DO4) for PDTPR 140 model  
 Type of outputs : Relay  
 Programmable (DO Assignment) : Yes  
 Relay reset type : Programmable (Auto/Manual)

### Input Contacts

No of digital inputs : 6 (DI1, DI2, DI3, DI4, DI5, DI6) for PDTPR 170 & 200 model  
 : 4 (DI1, DI2, DI3, DI4) for PDTPR 140 model  
 Type of inputs : AC/DC Voltage  
 Programmable (DI Assignment) : Yes

### 13.0 Human Machine Interface

PDTPR offers a variety of front user interfaces, including:

#### Human-Machine Interface (HMI)







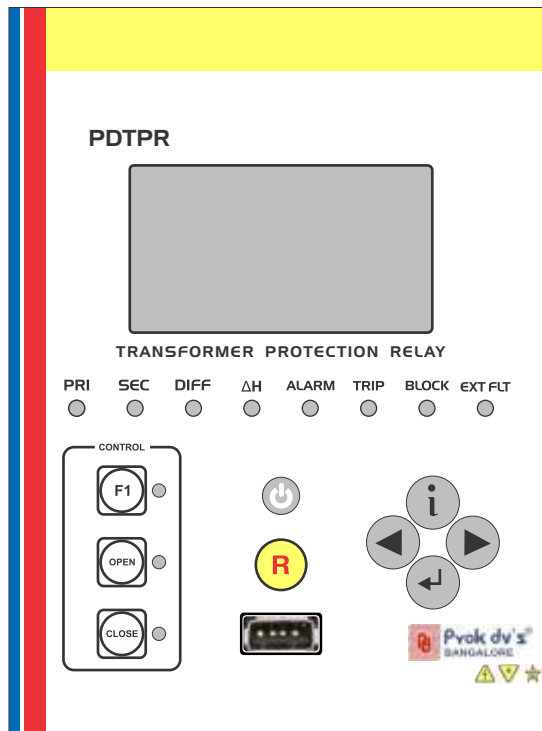

It comprises of alphanumeric display of 16x4 and 8 push buttons for setting and other operations for local access:

- ❖ Two push switches for set values of normal tripping characteristics.
- ❖ One 'RESET' push switch & One 'ENTER' push switch.
- ❖ One intelligent (i) Key.
- ❖ One push switch for the tripping of relay assigned to 'F1' Key.
- ❖ Two push switches for the tripping of relay assigned to Circuit breaker open & Circuit breaker close.
- ❖ Eight LEDs for pickup or tripping on fault's & events in any phase (See Figure-8).

In order to change any setting first press enter (↵) then only (◀/▶) key will act as increment / decrement else these key will function as scroll in forward / backward direction.



(Figure-8) HMI

Keys	Manual Key
	is used as intelligent key to see the details of the last fault.
	is used as a "ENTER" key.
	is used to manual reset (after pressing for 2 sec)
	is used to scroll in upward direction and for decrement of parameters.
	is used to scroll in downward direction and for increment of parameters.
	To perform the assigned task either DO Trip or Relay Reset.
	To Open the circuit breaker.
	To Close the circuit breaker.

## 14.0 Communication (Local & Remote)

The unit has:

- ❖ 1 Front USB port for direct connection to a PC.
- ❖ 1 Rear RS-485 communication port.
- ❖ 1 Rear terminal can be for: RJ-45 or plastic F.O.

### Rear Communication (RS-485)

The protocol for the rear port is programmable. The user can choose either MODBUS or IEC 870-5-103 protocol for RS485 communication.(See Table 15 for detailed description)

### Front Communication (USB)

The entire setting including protection parameter setting for both group, Fault, Event & Disturbance record are available on 'A' type USB (female) interface with CSE LIVELINK with saving & printing option (See Figure-10). This unit also has Front-end Live Link simulation support for testing of relay even without any three phase injection source.



(Figure-9) (communication setting for Front end utility)

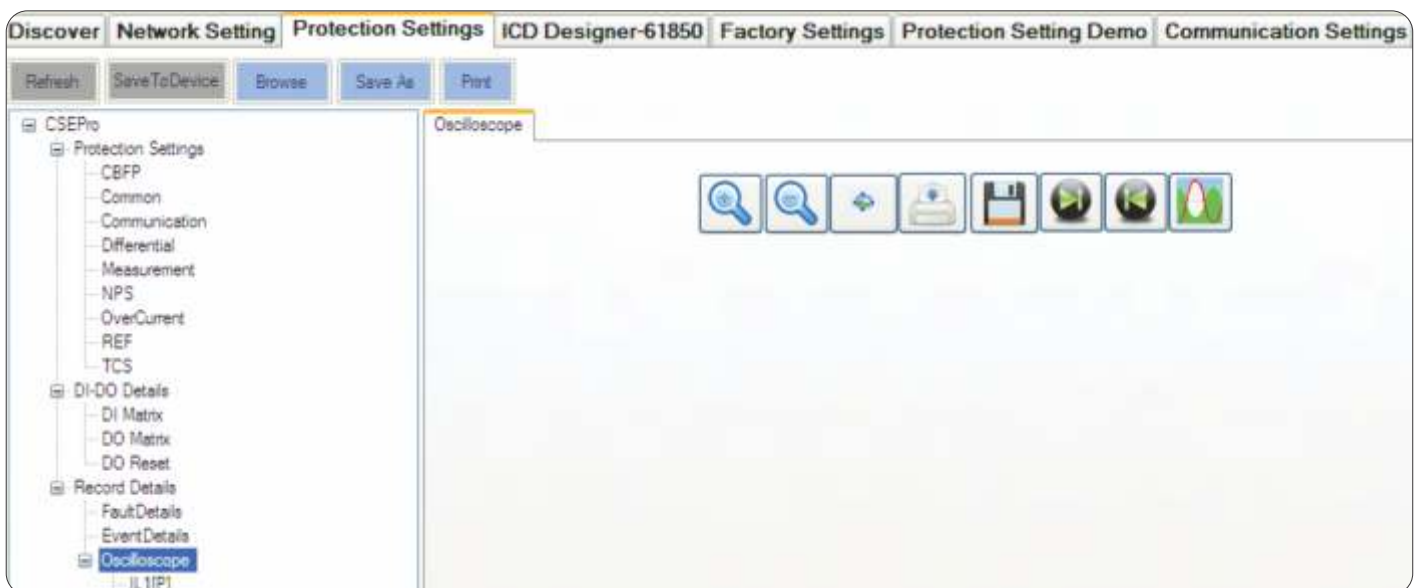

(Figure-10)

## 15.0 Setting Ranges

### Over-current Protection

Parameters	Display	Setting Range		Step Size	Default Setting
		Min	Max		
over-current pickup setting	I>	0.2xlp	4xlp	0.05	Disable
Phase characteristics	CURVE			DEFT,EINV,VINV, LINV, NINV1.3, NINV3.0 (1)	DEFT
over-current inverse timing	ti	0.01	1.5	0.005	0.010
over-current definite timing	t	0.1 Sec	150 Sec	0.01	0.10 Sec
Short circuit pickup setting	I>>	0.5xlp	40xlp	0.5	Disable
Short circuit definite timing	t	0.02 Sec	20 Sec	0.01	0.02 Sec

(Table-1)

### Earth Protection

Parameters	Display	Setting Range		Step Size	Default Setting
		Min	Min		
Earth pickup setting	Ie>	0.05xln	2.5xln	0.05	Disable
Earth characteristics	CURVE			DEFT,EINV,VINV,LINV, NINV1.3, NINV3.0(1)	DEFT
Earth inverse timing	ti	0.01	1.5	0.005	0.010
Earth definite timing	t	0.03 Sec	150 Sec	0.01	0.03 Sec
Earth hi-set pickup setting	Ie>>	0.5xln	8xln	0.05	Disable
Earth hi-set definite timing	t	0.02 Sec	20 Sec	0.01	0.02 Sec

(Table-2)

(1) Refer following formula for EINV, VINV, LINV, NINV1.3, NINV3.0 characteristics:

$$\text{Very Inverse} \quad t = \frac{13.5}{(I / IS) - 1} \quad t_i \text{ [s]}$$

$$\text{Extremely Inverse} \quad t = \frac{80}{(I / IS)^2 - 1} \quad t_i \text{ [s]}$$

$$\text{Long time Inverse} \quad t = \frac{120}{(I / IS) - 1} \quad t_i \text{ [s]}$$

$$\text{Normal Inverse 3.0/1.3} \quad t = \frac{0.14/0.061}{(I / IS)^{0.02} - 1} \quad t_i \text{ [s]}$$

Where  $t$  = Tripping time  $t_i$  = Time multiplier  
 $I$  = Fault current  $IS$  = Setting value of current

### Trip Circuit Supervision Protection

Parameters	Display	Setting Range		Step Size	Default Setting
		Min	Max		
Trip Circuit Supervision	td	0.03 Sec	2 Sec	0.01	Disable

(Table-3)

### Circuit Breaker Failure Protection

Parameters	Display	Setting Range		Step Size	Default Setting
		Min	Max		
Circuit breaker failure protection	tCBFP	0.03 Sec	2 Sec	0.01	Disable

(Table-4)

### Negative Phase Sequence Setting

Parameters	Display	Setting Range		Step Size	Default Setting
		Min	Max		
NPS pickup current	lb	0.50xlp	2.5xlp	0.1xlp	Disable
NPS characteristic	CHAR	DEFT	NPS-INV(2)	----	DEFT
Time multiple	K1	5 Sec	60 Sec	0.1 Sec	5.0 Sec
Time constant	K2	0.02	0.4	0.01	0.02
Definite time	td	0.02 Sec	0.4 Sec	0.01 Sec	0.02 Sec

(Table-5)

(2) Refer following formula for INV characteristics:

Negative Phase Sequence Equation

$$t = \frac{K1}{(I_2/I_b)^2 - (K_2)^2}$$

### Differential Protection Setting

Parameters	Display	Setting Range		Step Size	Default Setting
		Min	Max		
<b>Percentage Differential Protection</b>					
Enable Differential Protection	DIFFR	Disable	Enable		Disable
Min. Pickup Current	m0 (3)	0.04	1.00	0.01	0.12
1st Slope	m1 (3)	10%	100%	1%	20%
2nd Slope	m2 (3)	10%	100%	1%	20%
Start point of 1st slope	K1 (3)	0.04	2.00	0.01	0.24
Start point of 2nd slope	K2 (3)	1	10	0.02	1.30
Vector Group	Vect Grp			Yd1/Yd3/Yd5/ Yd7/Yd9/Yd11/ Dy1/Dy3/Dy5/ Dy7/Dy9/Dy11/ YY0/DD0/YY2/ DD2/YY4/DD4/ YY6/DD6/YY8 DD8/YY10/DD10	YY0
Primary CT correction factor (PriCTcorr)	PriCTcor	0.2	4.0	0.01	1.00
Secondary CT correction factor (SecCTcorr)	SecCTcor	0.2	4.0	0.01	1.00
Added delay (Lo-set)	td>	0 Sec	60 Sec	0.01 Sec	0.00 Sec
Hi-set setting(Hi-Set)	HiSet	5xlp	20xlp	1xlp	Disable
Hi-set delay	td>>	0.02 Sec	60 Sec	0.01 Sec	0.02 Sec

(Table-6)

**Note: (3)**

Refer Figure-3 for settable parameters of different trip characteristic  
(Always ensure that  $m_0 < k_1$  and  $k_1 < k_2$ ).

**Harmonic Restrain**

Parameters	Display	Setting Range		Step Size	Default Setting
		Min	Max		
2nd harmonic blocking limit	2nd H	20% If	50% If	5% If	Disable
5th harmonic blocking limit	5th H	20% If	50% If	5% If	Disable
3rd harmonic blocking limit	3rd H	20% If	50% If	5% If	Disable
Protection blocked, if harmonic in all 3 Ph/1Ph	Phase	1 Phase	3 Phase	-	1 Phase
Differential protection blocking on harmonic	DIFF_BLK	Disable	Enable	-	Enable
Over-current protection blocking on harmonic	OC_BLK	Disable	Enable	-	Disable
Short circuit protection on harmonic	SC-BLK	Disable	Enable	-	Disable
Negative phase sequence on harmonic	NPS_BLK	Disable	Enable	-	Disable
Earth Low on harmonic	EL_BLK	Disable	Enable	-	Disable
Earth High on harmonic	EH_BLK	Disable	Enable	-	Disable
Restricted earth protection on harmonic	REF_BLK	Disable	Enable	-	Disable

(Table-7)

**Restricted Earth Protection**

Parameters	Display	Setting Range		Step Size	Default Setting
		Min	Max		
Restricted Earth Fault Protection (Only star side will be protected)					
Enable REF protection	REF	Disable	Enable	-	Disable
Min. REF pickup	m0_REF(4)	0.04	1	0.02	0.14
REF first slope	m1REF(4)	10%	100%	1%	20%
Start point of slope	k1_REF(4)	0.04	3	0.02	0.34
Added delay	td	0 Sec	60 Sec	0.01 Sec	0.00 Sec
Earth CT correction factor	ECTcorr	0.1	4	0.01	1.00
Protection on Pri or Sec winding	Winding	Primary	Secondary	-	Primary

(Table-8)

**Note: (4)** (4) Refer Figure-4 for settable parameters of restricted earth fault (REF) trip characteristic  
Always ensure that  $m1REF < k1\_REF$

**DI Assignment \***

All the 6 DI (DI1, DI2, DI3, DI4, DI5, DI6) for PDTPR-200 &170 model & 4 DI (DI1, DI2, DI3, DI4) for PDTPR-140 can be programmed for any or all the following task:

Parameters	Display	Default Setting
Circuit breaker close	CB_CLOSE	-----
Circuit breaker open	CB_OPEN	-----
Remote trip-1	RmtTrp1	-----
Remote trip-2	RmtTrp2	-----
Remote trip-3	RmtTrp3	-----
Remote trip-4	RmtTrp4	-----
Remote trip-5	RmtTrp5	-----
Remote trip-6	RmtTrp6	-----
Group toggling	GRP TOGG	-----
Remote reset	RMT RSET	-----
Oscilloscope record triggering	OSC TRIG	-----
Over-current blocking	OC BLK	-----
Short circuit blocking	SC BLK	-----
Earth timed blocking	EL BLK	-----
Earth instant blocking	EH BLK	-----
Differential blocking	DIFL BLK	-----
Differential hi-set blocking	DIFH BLK	-----
REF blocking	REF BLK	-----
NPS blocking	NPS BLK	-----

(Table-9)

**DO Assignment \***

All the 6 DO (DO1, DO2, DO3, DO4, DO5, DO6) for PDTPR-200 &170 model & 4 DO (DO1, DO2, DO3, DO4) for PDTPR-140 can be programmed for any or all the following task:

Parameters	Display	Default Setting
Over-current protection	I>	-----
Short circuit protection	I>>	-----
Earth timed protection	Ie>	-----
Earth instant protection	Ie>>	-----
Percentage differential protection	Id>	-----
Differential hi-set protection	Id>>	-----
Restricted earth fault protection	Iref>	-----
Negative phase sequence protection	I2>	-----
Trip circuit supervision	74TC	-----
Circuit breaker failure protection	CBFP	-----
Circuit breaker open	CB OPEN	-----
Circuit breaker close	CB CLOSE	-----
Remote trip-1	RmtTrp1	-----
Remote trip-2	RmtTrp2	-----
Remote trip-3	RmtTrp3	-----
Remote trip-4	RmtTrp4	-----
Remote trip-5	RmtTrp5	-----
Remote trip-6	RmtTrp6	-----
Self supervision	SLF SPVSN	-----

(Table-10)

### DO RESET Mode \*

The entire 6 DO (DO1, DO2, DO3, DO4, DO5, DO6) for PDTPR-200 & 170 model & 4 DO (DO1, DO2, DO3, DO4) for PDTPR-140 can be programmed to reset either in Auto or in Manual mode.

Parameters	Display	Setting Range		Default Setting
		Min	Max	
Relay 1	DO1	Auto	Manual	Auto
Relay 2	DO2	Auto	Manual	Auto
Relay 3	DO3	Auto	Manual	Auto
Relay 4	DO4	Auto	Manual	Auto
Relay 5	DO5	Auto	Manual	Auto
Relay 6	DO6	Auto	Manual	Auto

(Table-11)

\* **Note:** These are the model dependent and are available in auxiliary models only.

### Key Assignment

Relay is having one function key (F1). It can be assign to trip any of 6 DO or to reset the PDTPR relay.

Parameters	Display	Setting	Default Setting
Function key	F1	DO1/DO2/DO3/DO4/DO5/DO6/DO RESET	DO0

(Table-12)

### General Setting

These are the setting's common for all the protections:

Parameters	Display	Setting Range		Step Size	Default Setting
		Min	Max		
Common setting	-----			-----	
Rated phase current for HV side	Ip [P]	1.00 Amp	5.00 Amp	-----	1.0 Amp
Rated phase current for LV side	Ip [S]	1.00 Amp	5.00 Amp	-----	1.0 Amp
Rated earth current	In	1.00 Amp	5.00 Amp	-----	1.0 Amp
Primary CT ratio	PriCTRatio	1	10000	1	1
Secondary CT ratio	SecCTRatio	1	10000	1	1
Earth CT ratio	E CT Ratio	1	10000	1	1
Nominal frequency	Nom.FREQ	50 Hz	60 Hz	-----	50 Hz

(Table-13)

### Oscilloscope (Disturbance) Record Setting

These are the settings for Oscilloscope recording:

Parameters	Display	Setting Range		Step Size	Default Setting
		Min	Max		
Oscilloscope recording selection	RECORD	NO	YES	-----	NO
Pre-fault cycle	PRE CYCLE	2	298	1	2 Cycle
Post-fault cycle	POST CYCLE	2	298	1	2 Cycle
Triggering mode	TRIG. MODE	PK-UP	PK-UP/TRIP/DI/ anyone	-----	PK-UP

(Table-14)



### Rear Port Communication Setting (\*Availability as per model selection)

RS-485 Communication			Default Setting
Protocol	:	MODBUS RTU / IEC-103	MODBUS
Baud rate selection (programmable)	:	4800 / 9600 / 19200 / 38400 / 57600 bps	19200 bps
Parity selection (programmable)	:	Even / Odd / None	None
Stop bit	:	1 Bit	1 Bit
Data bit	:	8 Bit data	8 Bit data
Remote address (programmable)	:	(1 to 32)	1
Cable required for interface	:	Two wire twisted shielded cable	-----

(Table-15)

USB Communication		
Protocol	:	Proprietary Protocol: available with front software
Baud rate	:	19200 bps
Cable required for Interface	:	USB cable type (A to A)

(Table-16)

## 16.0 Technical Data

### Measuring Input

Rated Data		Rated current $I_p$ : 1A & 5A Rated frequency $F_n$ : 50Hz/60Hz
Thermal withstand capability in current circuit		At $I_p = 1A$ Continuous = $5 \times I_p$ for 10 Sec = $30 \times I_p$ for 1 Sec = $100 \times I_p$
		At $I_p = 5A$ Continuous = $3 \times I_p$ for 10 Sec = $10 \times I_p$ for 1 Sec = $20 \times I_p$
Nominal burden		For phase = $<0.2VA$ For earth = $<0.2VA$

(Table-17)

### Measurement Accuracy

Parameters	Range	Frequency Range	Accuracy
Current in Ampere	1.0-40xIn	50-60Hz	Less than $\pm 2\%$

(Table-18)

### Trip Time Accuracy

Parameters	Accuracy
Trip time accuracy for differential Hi-set	+10mSec OR +5% (whichever is higher)
AND	
Trip time accuracy for all other protections	+30mSec OR +5% (whichever is higher)

(Table-19)

### Relay Contact Rating

Contact rating	
Contact relay	Dry contact Ag Ni
Make current	Max. 30A & carry for 3S
Carry capacity	8A continuous
Rated voltage	250V AC
Breaking characteristics	
Breaking capacity AC	1500VA resistive 1500VA inductive (PF=0.5) 220V AC, 5A (cosØ=0.6)
Breaking capacity DC	135V DC, 0.3A (L/R=30ms) 250V DC, 50W resistive or 25W inductive (L/R=40ms)
Operation time	<7ms
Durability	
Loaded contact	10000 operation minimum
Unloaded contact	10000 operation minimum

Over-voltage category : II  
Insulation voltage : 300V  
Pollution Degree : 2  
IP54 from Front

(Table-20)

### Auxiliary Supply

Rated auxiliary voltage UH	For 'L' Model	18V-60V DC
	For 'W1' Model	18V-150V DC
	For 'H' Model	85V-280V AC / 110V-300V DC
Rated supply for digital input	Normal Voltage UN	80V-260V AC (Active)
	For 'H' Model	48V-300V DC (Active)
		<30V DC (Inactive)
		<50V AC (Inactive)
	Normal Voltage UN	24V - 60V DC (Active)
	For 'L' Model	<18V DC (Inactive)
Power consumption	Quiescent approx. 3W	Operating approx. <7W

(Table-21)

### Common Data

Dropout ratio	:	> 96%
Relay Reset time	:	30 ms
Minimum operating time	:	30 ms
Transient overreach at instantaneous operation	:	£5 %

(Table-22)

## 17.0 Standards

### Design Standards

IEC 60255-22-[1-6]

IEC 60255-5

### 17.1 HIGH VOLTAGE TESTS:

#### High Frequency Interference Test

IEC 60255-22-1	:		
Class 3	:	Auxiliary Supply	2.5 kV/2 s
	:	Circuit to Earth	2.5 kV/2 s

#### Dielectric Voltage Test

IEC 60255-5/EN 50178	:	i) All Input/ Output circuits to Earth	2.5 kV (eff)/50Hz, 1 min.
	:	ii) Between Input & Output Circuits	

#### Impulse Voltage Test

IEC 60255-5	:	i) All Input/ Output circuits to Earth	5kV / 0.5J, 1.2/50 $\mu$ s
	:	ii) Between Input & Output Circuits	

### 17.2 EMC IMMUNITY TESTS

#### Fast Transient Disturbance Immunity Test (Burst)

IEC 60255-22-4	:	Power supply, mains inputs	+4 kV, 2.5 kHz
IEC 61000-4-4	:		
Class 4	:	Other in and outputs	+2 kV, 5 kHz

#### Surge Immunity Test

IEC 61000-4-5	:	Within one circuit	2 kV, Differential Mode, Level 4
Class 4	:		
	:	Circuit to Earth	4 kV, Common Mode, Level 4

#### Electrical Discharge Immunity Test

IEC 60255-22-2	:	Air discharge	8 kV
IEC 61000-4-2	:		
Class 3	:	Contact Discharge	6 kV

#### Radiated Immunity Test

EN 61000-4-3 / IEC60255-22-3 :	Level 3, 10V/m 80MHz to 1GHz @ 1kHz 80% AM
--------------------------------	--

#### Conducted Immunity Test

EN 61000-4-6 / IEC 60255-22-6 :	Level 3, 10V rms @ 1kHz 80% AM, 150KHz to 80Mhz
---------------------------------	---

#### Power Frequency Magnetic Field Immunity Test

IEC 61000-4-8 :	Level 5, 100A/m applied continuously, 1000A/m for 3s.
-----------------	---

### EMC Emission Tests

#### Radio Interference Suppression Test

IEC 60255-25/EN55011/CISPR11	Limit value class A
------------------------------	---------------------

0.15 - 0.5MHz, 79dB $\mu$ V (quasi peak) 66dB $\mu$ V (average)

0.5 - 30MHz, 73dB $\mu$ V (quasi peak) 60dB $\mu$ V (average)

### Radio Interference Radiation Test

IEC-60255-25/EN55011/CISPR11

Limit value class A

30 - 230MHz, 40dB V/m at 10m measurement distance

230 - 1GHz, 47dB V/m at 10m measurement distance

### 17.3 ENVIRONMENTAL TESTS

#### Temperature

IEC 60068-2-1

Storage -25°C to +85°C

IEC 60068-2-2

Operation: -25°C to + 70°C

#### Test Bd: Dry Heat

IEC 60068-2-2

: Temperature

55°C

: Relative humidity

<50%

: Test duration

72 h

#### Test Bd: Dry Heat

IEC 60068-2-2

: Temperature

70°C

: Relative humidity

<50%

: Test duration

2 h

(The clearness of the display is constricted)

#### Test Db: Damp Heat (Cyclic)

IEC 60068-2-30

: Temperature

55°C

: Relative humidity

95%

: Cyclic duration (12 + 12 Hours)

2

### 17.4 MECHANICAL TESTS

#### Test: Vibration Response Test

IEC 60068-2-6

: (10Hz – 59Hz)

0.035 mm

IEC 60255-21-1

displacement

Class 1

: (59Hz-150Hz)

0.5 gn

Acceleration

: No. of cycles in each axis

1

#### Test: Vibration Endurance Test

IEC 60068-2-6

: (10Hz-150Hz)

1.0 gn

IEC 60255-21-1

Acceleration

Class 1

: No. of cycles in each axis

20

#### Test: Shock Tests

IEC 60068-2-27

: Shock response test

5 gn, 11 ms, 3 impulses in each direction

IEC 60255-21-2

Class 1

: Shock resistance test

15 gn, 11 ms, 3 impulses in each direction

#### Test: Shock Endurance Test

IEC 60068-2-29

: Shock endurance test

10 gn, 16 ms, 1000 impulses in each direction

IEC 60255-21-2

Class 1

### 18) Trip Circuit Supervision Diagram

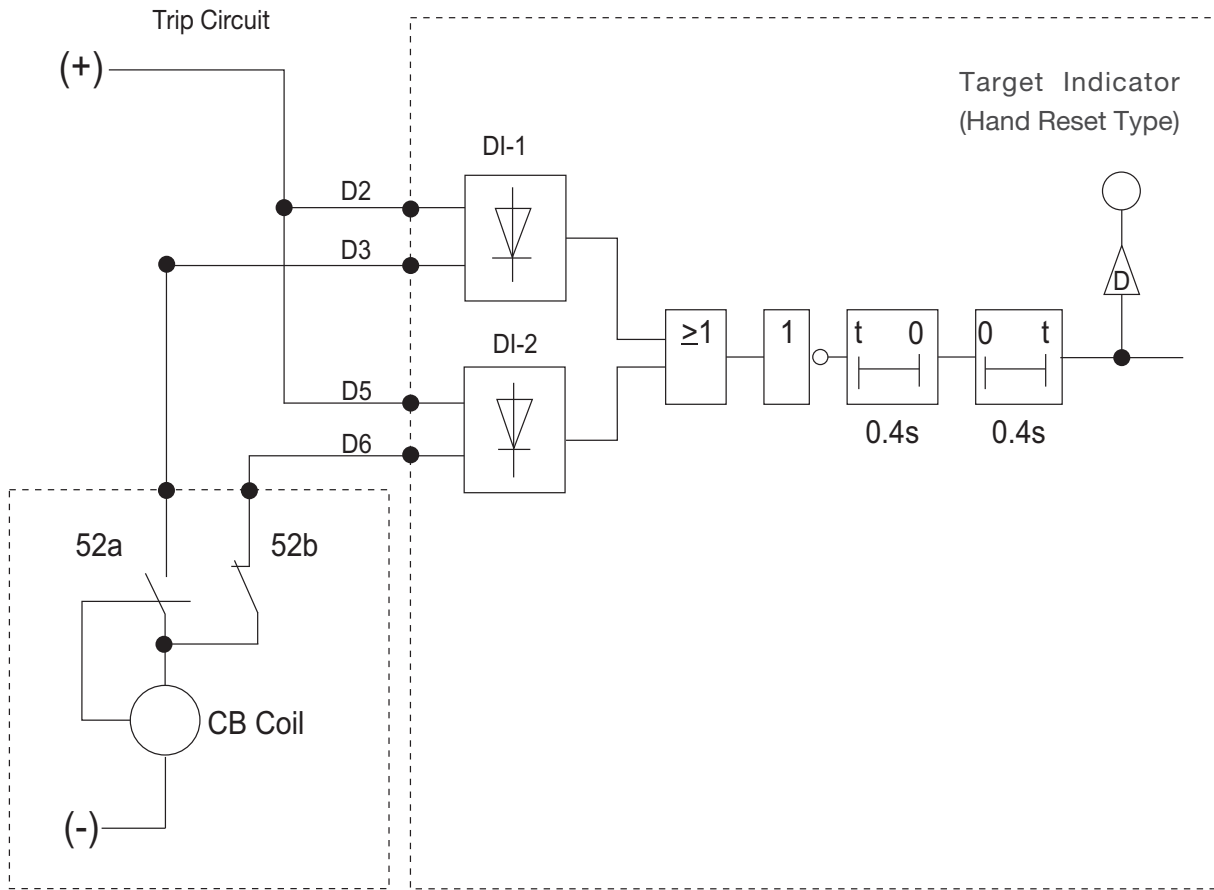

(Figure 11) (Trip Circuit Supervision Function)

### 19.0 Connection Diagram

PDTPR-140

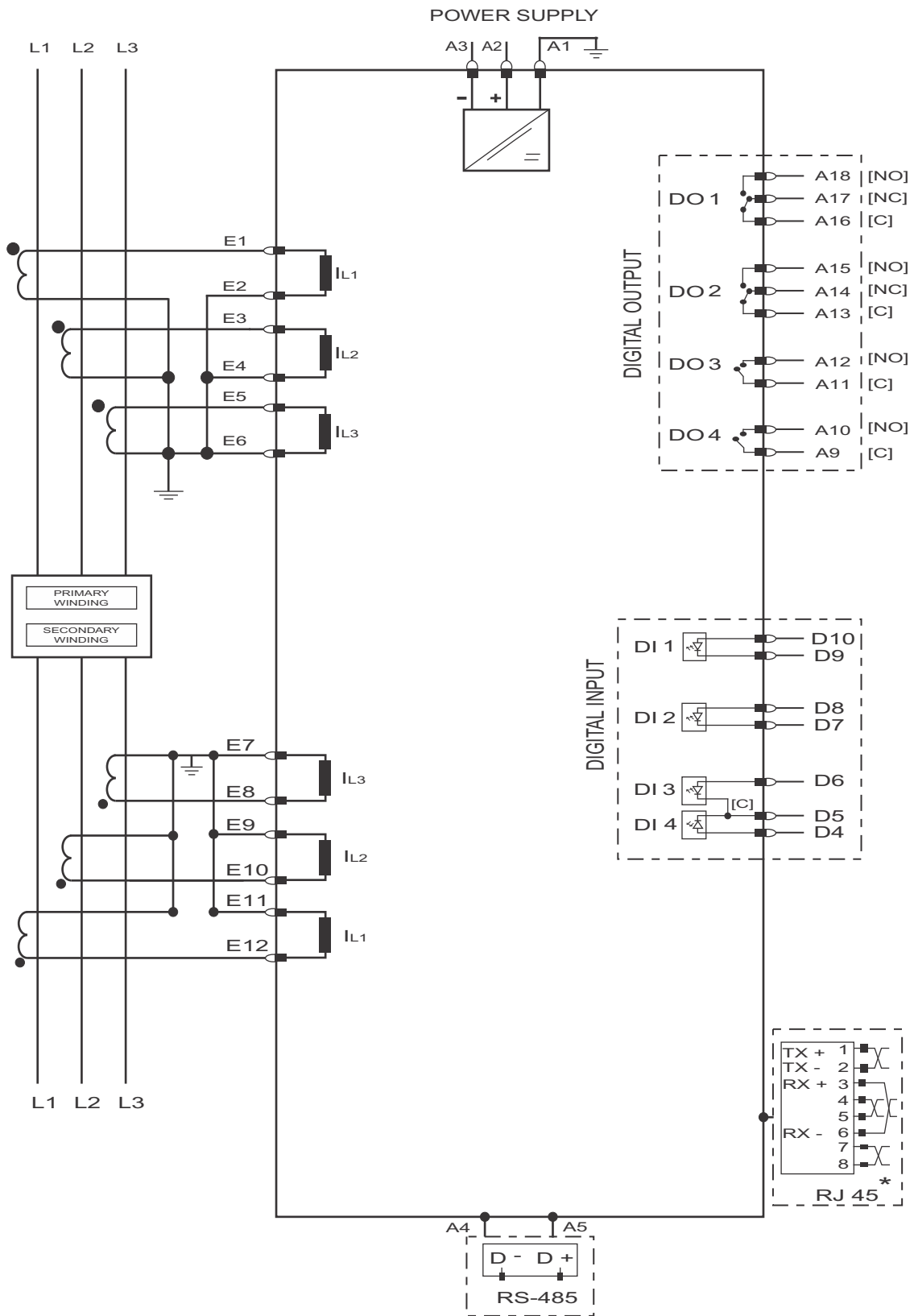

(Figure-12)

**Connection Diagram**

**PDTPR-170**

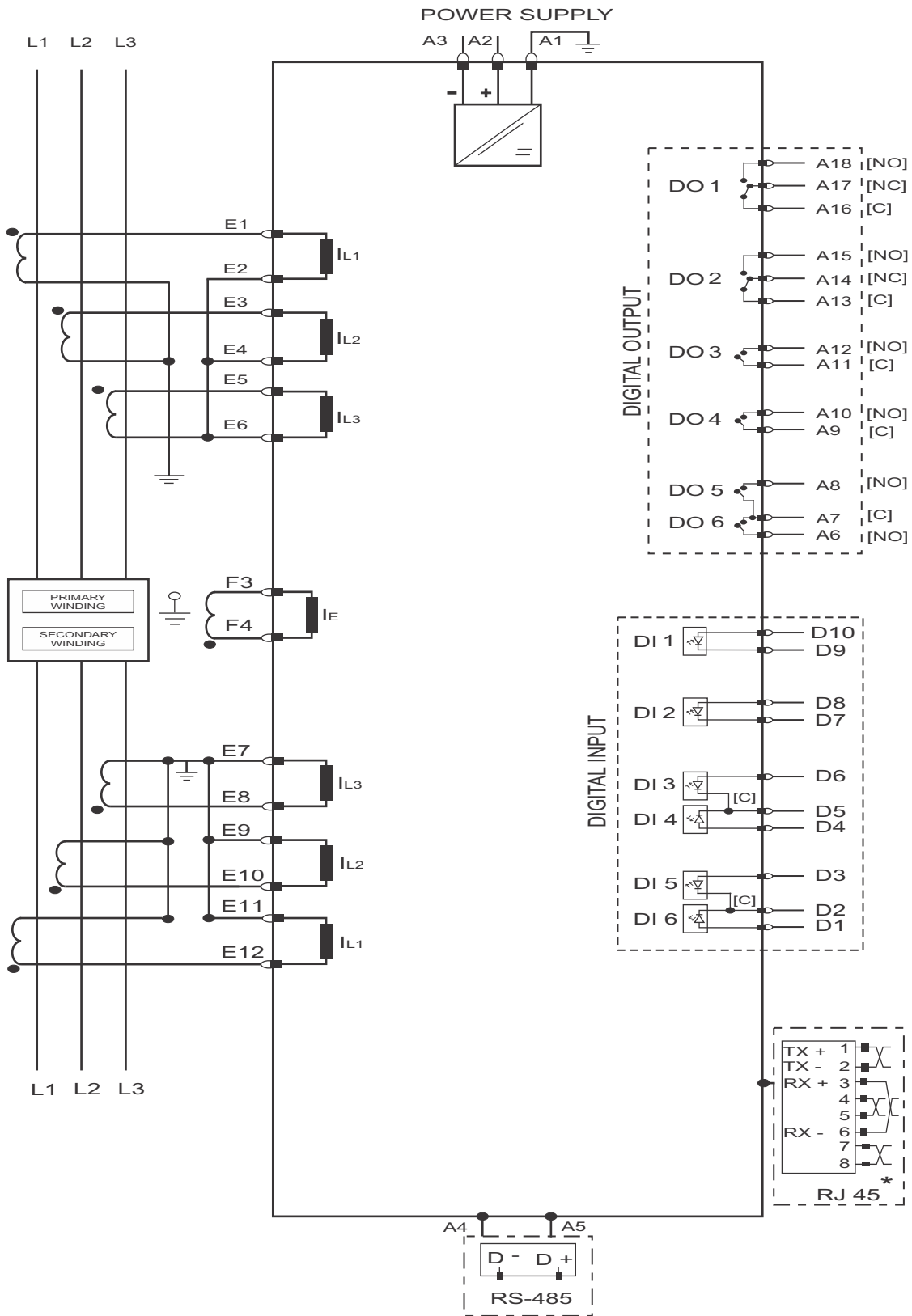

(Figure-13)

**Connection Diagram**

**PDTPR-200**

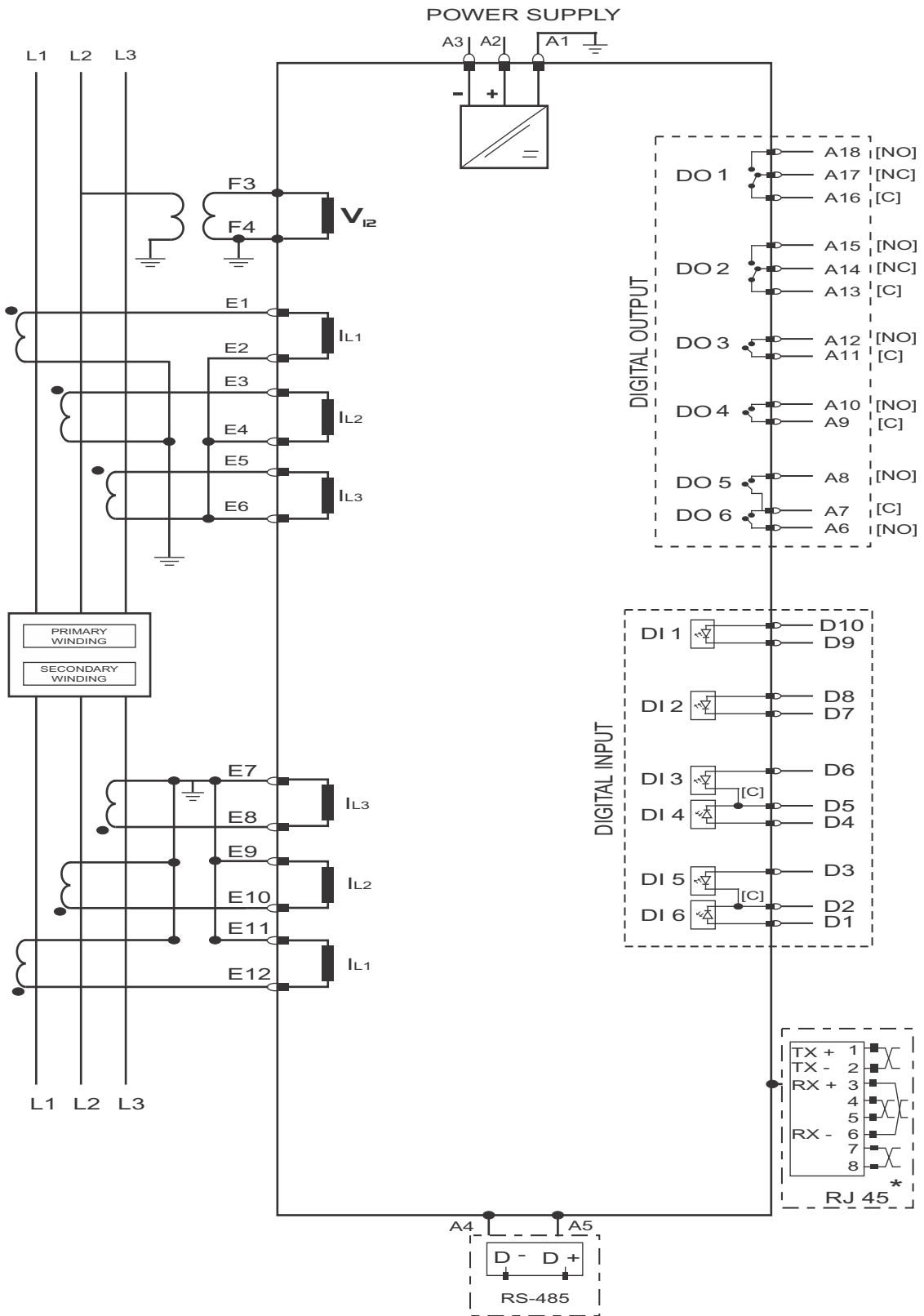

(Figure-14)



## 20.0 Dimension Details

Panel cut out dimension: WxH = 112.0x145.0mm

Front View

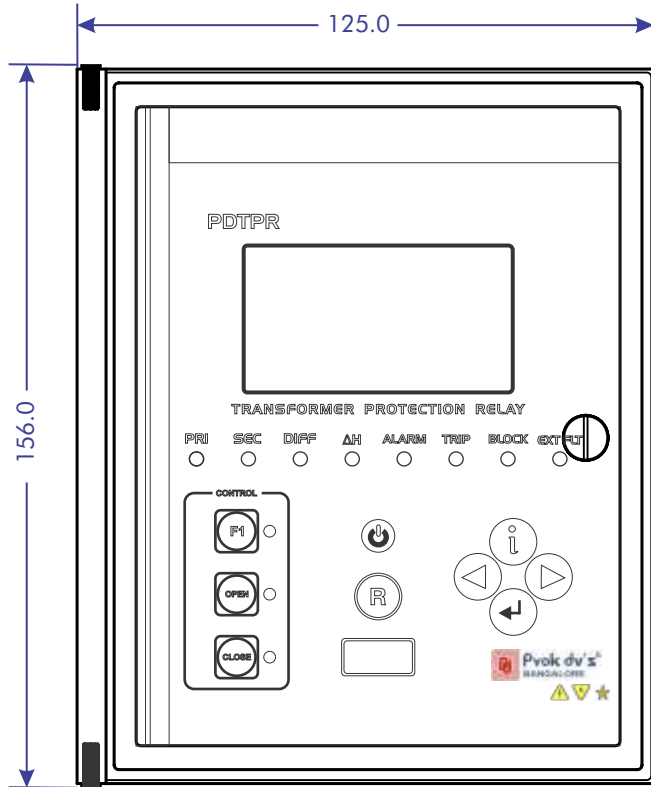

(Figure-15)

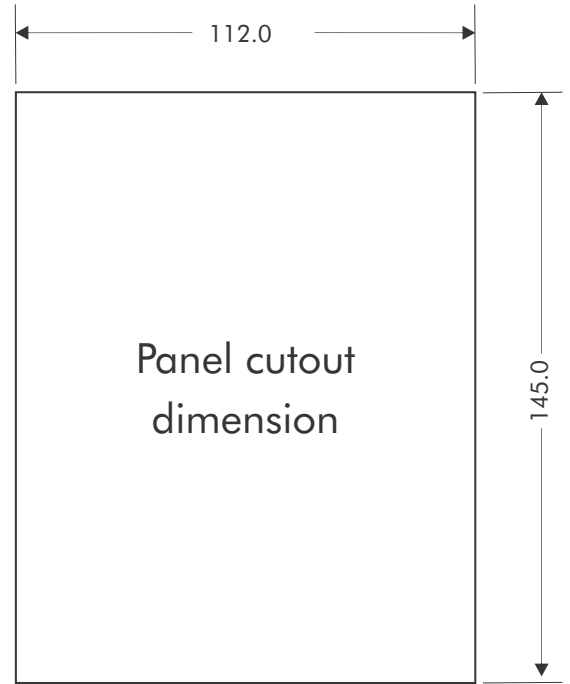

(Figure-16)

Side View

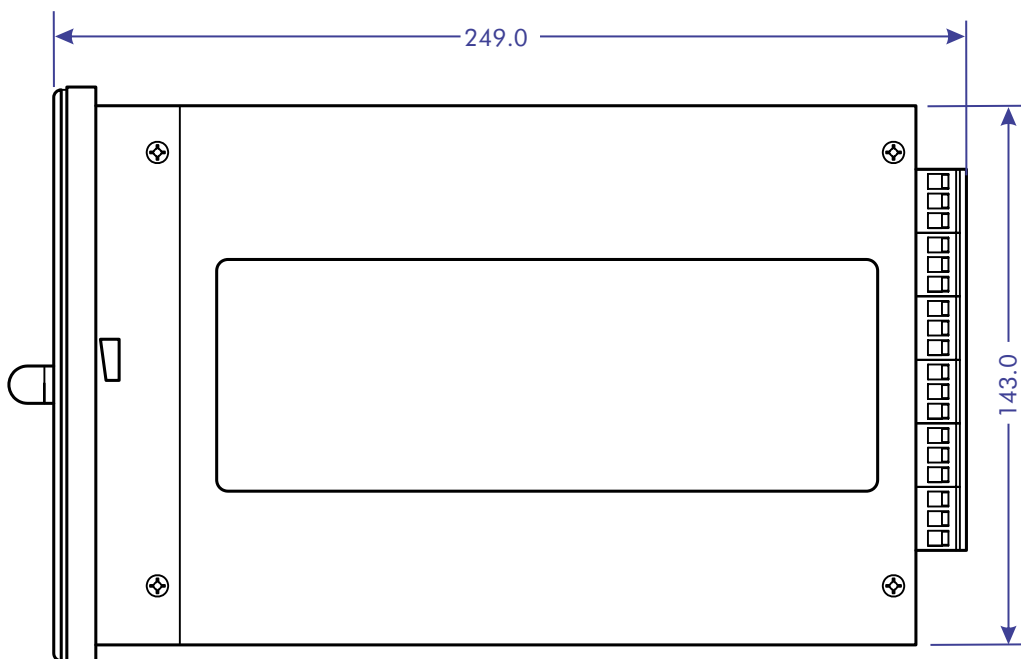

(Figure-17)

## 21.0 Model Selection Table

PDTPR-XXX-Series	ANSI	PDTPR140	PDTPR170	PDTPR200
CT Inputs		6	7	6
VT Inputs		-	-	1
Opto Inputs		4	6	6
Output Contacts		4	6	6
Function Keys/Hotkeys		●	●	●
Programming Logic		-	-	●
<b>Protection</b>				
Transformer Differential	87P	●	●	●
Windings		2	2	2
Restricted Earth Fault	87G	-	●	-
Over fluxing/5th Harmonic		●	●	●
Over excitation	24	-	-	●
2nd Harmonic Restraint		●	●	●
Phase Over-current	50/51P	●	●	●
Ground Fault	50/51N	-	●	-
Negative Sequence Over-current	46	●	●	●
Thermal Over load	49	-	-	●
Circuit Breaker Failure	50BF	●	●	●
Trip Circuit Supervision	74TC	●	●	●
<b>Communication</b>				
Front (USB)		●	●	●
Rear RS-485 Modbus		●	●	●
Modbus on Fiber Optics		○	○	○
RJ-45 Modbus TCP/IP		○	○	○
IEC 60870-5-103 on Fiber Optics		○	○	○
RJ-45 IEC 60870-5-101		○	○	○
RS-485 IEC 60870-5-103		○	○	○
RJ-45 IEC 61850		○	○	○
SNTP-Time Synch-RJ-45		○	○	○
Web server on RJ-45		○	○	○

○ Optional-Based on Ordering Information

(Table-22)

Variants in PDTPR	Relay Type	Protection	DI/DO	Communication
PDTPR-140	2 winding differential protection	87P, 50/51P, 50/51N, 46, 74TC	4/4	USB+RS-485
PDTPR-170	2 winding differential with REF	87P, 87G, 50/51P, 50/51N, 46, 74TC	6/6	USB+RS-485
PDTPR-200	2 winding differential with over excitation	87P, 24, 50/51P, 46, 49, 74TC	6/6	USB+RS-485

(Table-23)

## 22.0 Ordering Information

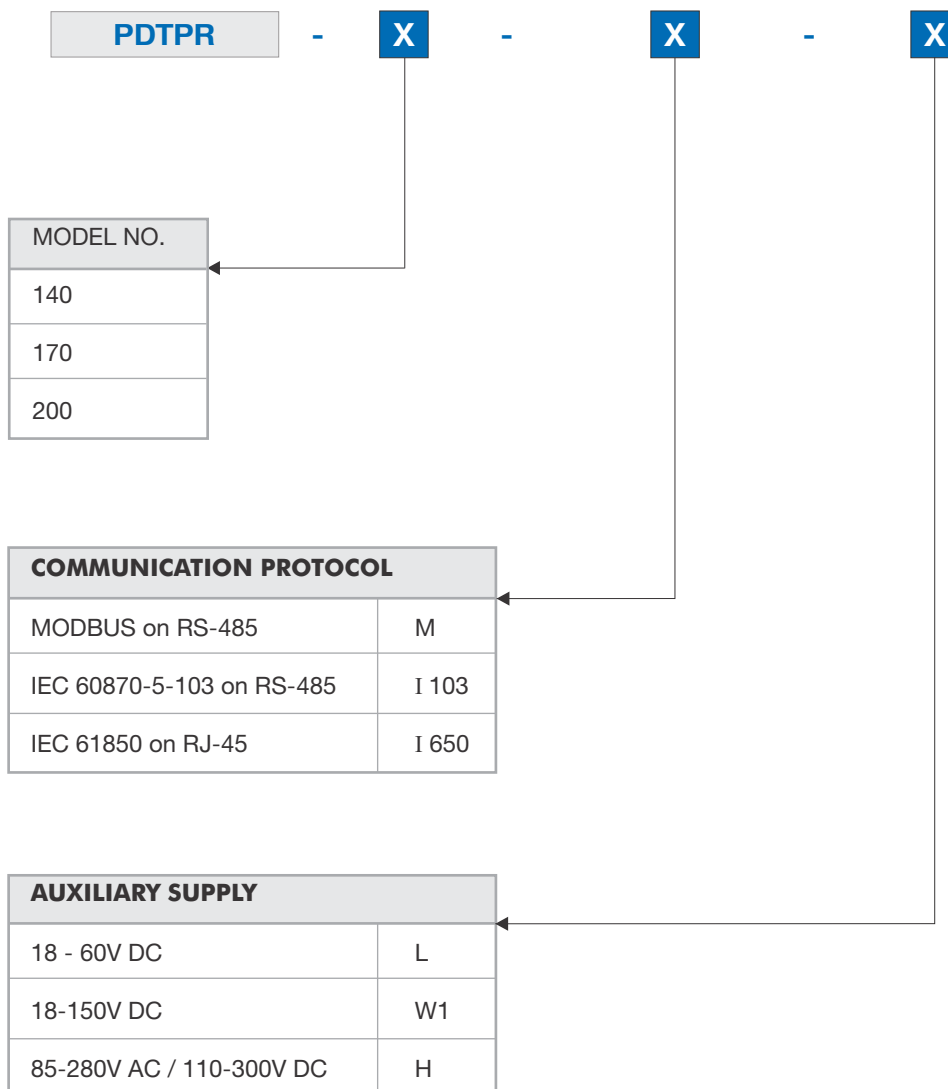

**Example : PDTPR-170-M-L**

